

Type: VSR-M

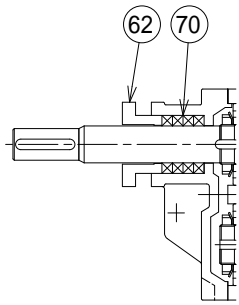

Type: VSR

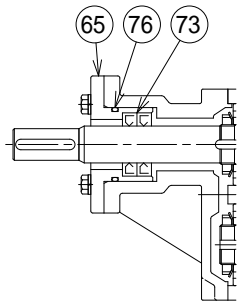

Type: VSR-S

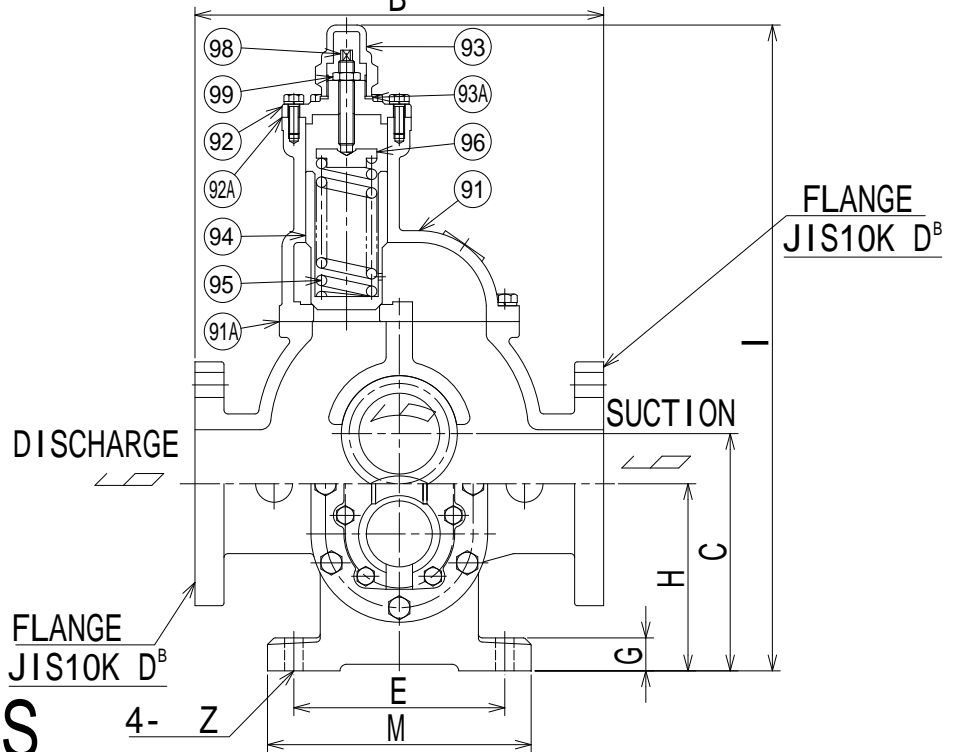

73	MECH. OIL SEAL	2	NBR	70	GLAND PACKING	1SET	CARBONIZED FIBER	25	BEARING WASHER	4	SS400
				62	GLAND	1	FC250	24	BEARING NUT	4	SS400
								23	BALL BEARING	8	SUJ
99	RV. LOCK NUT	1	SS400	89	MECH. B. OIL SEAL	1	NBR	19	SIDE PLATE	4	FC250
98	RV. ADJUST. SCREW	1	SS400	82	MECH. COUPLER	1	SUS304	14	GEAR	2	S45C
96	RV. SP. SUPPORTER	1	S45C	81	MECH. THRUST BEARING	1	SUJ	10	DRIVEN SHAFT	1	S45C
95	RV. SPRING	1	SWP	78	MECH. SPRING	1	SWP	9	DRIVE SHAFT	1	S45C
94	RV. VALVE	1	FC250	77	MECH. PACKING	2	PTFE	5A	REAR COVER PACKING	1	PACKING PAPER
93A	RV. CAP PACKING	1	CARBON FIBER	76	MECH. O-RING	1	NBR	5	REAR COVER	1	FC250
93	RV. CAP	1	FC250	75	MECH. ROTATION RING	1	SUS304/METC016C	4	F. B. COVER	1	FC250
92A	RV. COVER PACKING	1	CARBON FIBER	74	MECH. SEAL RING	1	CARBON	2A	FRONT COVER PACKING	1	PACKING PAPER
92	RV. COVER	1	FC250	65	GLAND COVER	1	FC250	2	FRONT COVER	1	FC250
91A	RV. CASE PACKING	1	PACKING PAPER	61	GLAND CASE	1	FC250	1A	CASE PACKING	2	PACKING PAPER
91	RELIEF VALVE CASE	1	FC250	60	KEY	1	S45C	1	CASE	1	FC250
No.	NAME	QUANT.	MATERIAL	No.	NAME	QUANT.	MATERIAL	No.	NAME	QUANT.	MATERIAL