

Type:  
KR-S

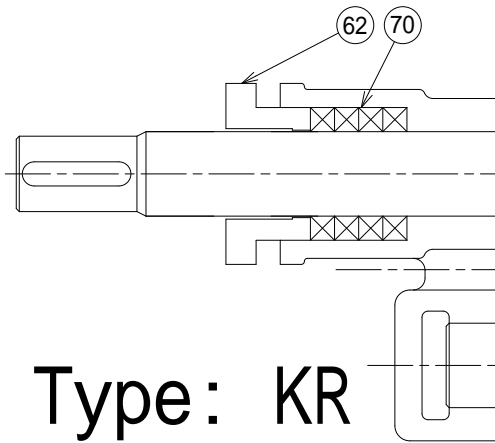

Type: KR

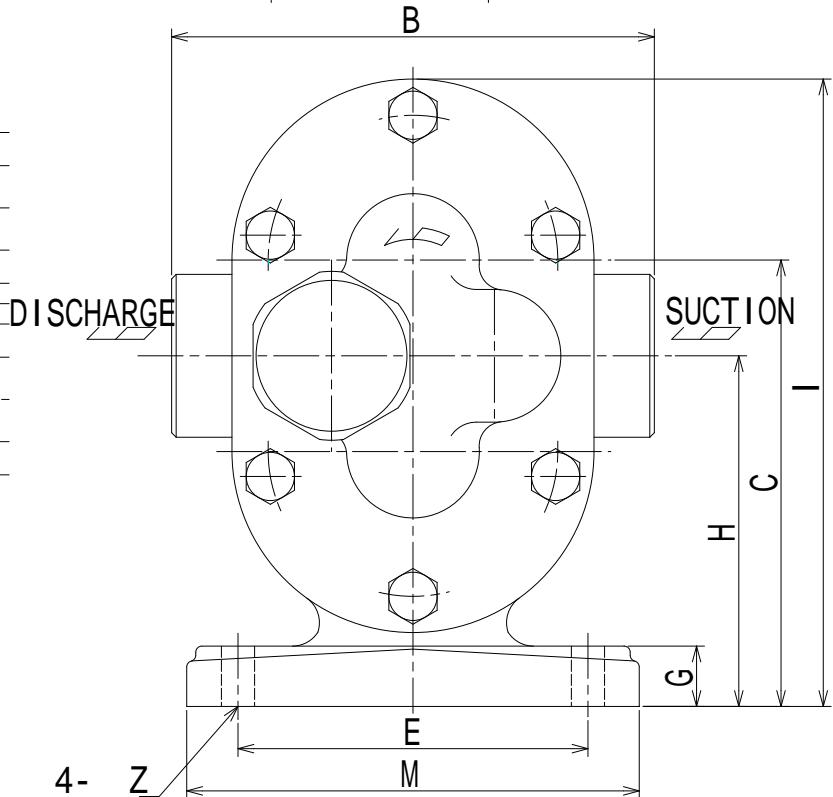

				97	RV. GUIDE SCREW	1	S45C	60	KEY	1	S45C
				95	RV. SPRING	1	SWP				
				94	RV. VALVE	1	S45C	14	GEAR	2	S45C
				93A	RV. CAP PACKING	1	URETHANE	10	DRIVEN SHAFT	1	S45C HARDENING
				93	RV. CAP	1	FC250	9	DRIVE SHAFT	1	S45C HARDENING
								5	REAR COVER	1	FC250
				76	MECH. O-RING	1	NBR	2	FRONT COVER	1	FC250
				73	MECH. OIL SEAL	2	NBR	1A	CASE PACKING	2	PACKING PAPER
				64	GLAND METAL	1	BC6	1	CASE	1	FC250
No.	NAME	QUANT.	MATERIAL	No.	NAME	QUANT.	MATERIAL	No.	NAME	QUANT.	MATERIAL