

HPR-M₂型
(ダブルメカニカルシール式)

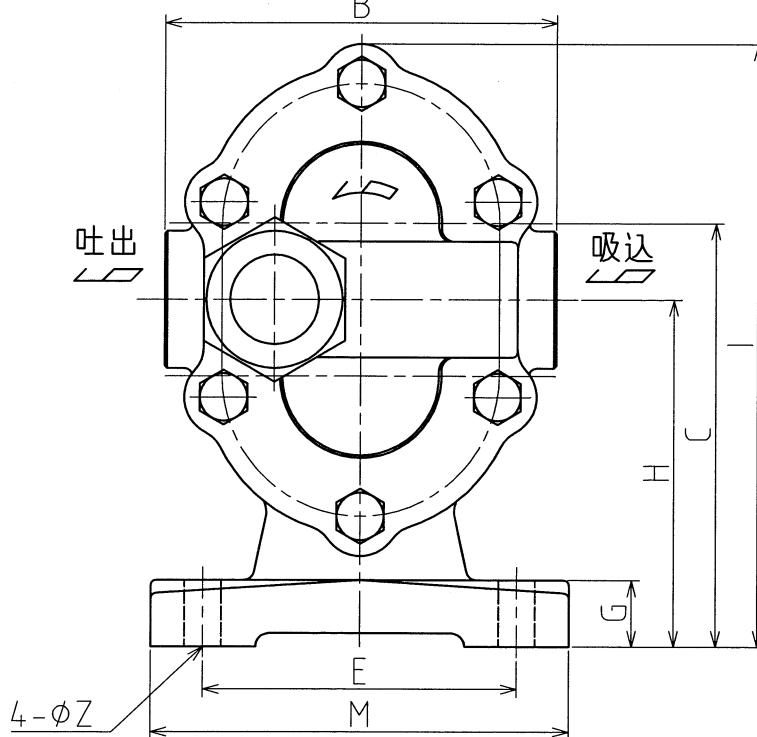

								65	GLAND COVER	1	FC250
								61	GLAND CASE	1	FC250
				89	MECH. B. OIL SEAL	1	NBR	60	KEY	1	S45C
99	RV. LOCK NUT	1	SS400	88	MECH. B. STOP RING	1	SWP	18	SIDE PLATE METAL	4	BC6
98	RV. ADJUST. SCREW	1	SS400	86	MECH. BALL BEARING	1	SUJ	14	GEAR	2	S45C
97	RV. GUIDE SCREW	1	S45C	82	MECH. COUPLER	2	SUS304	10	DRIVEN SHAFT	1	SCM435H HARDENING
96	RV. SP. SUPPORTER	1	S45C	78	MECH. SPRING	1	SWP	9	DRIVE SHAFT	1	SCM435H HARDENING
95	RV. SPRING	1	SWP	77	MECH. PACKING	4	PTFE	5	REAR COVER	1	FC250
94	RV. VALVE	1	S45C	76	MECH. O-RING	2	NBR	2	FRONT COVER	1	FC250
93A	RV. CAP PACKING	1	ARAMID FIBER	75	MECH. ROTATION RING	2	SUS304/METC016C	1A	CASE PACKING	2	PACKING PAPER
93	RV. CAP	1	FC250	74	MECH. SEAL RING	2	CARBON	1	CASE	1	FC250
No.	NAME	QUANT.	MATERIAL	No.	NAME	QUANT.	MATERIAL	No.	NAME	QUANT.	MATERIAL